

**Bulletin 10-23-4**  
**Grounding & bonding in farms**  
**Rules 10-210 d) and 10-700**

**Issued May 2022**  
Supersedes Bulletin 10-23-3

**Scope**

- 1) Background
- 2) Equipotential bonding in milking areas
- 3) Grounding and bonding for farm buildings
  - a) Farm service
  - b) Central Metering System – grounding at individual buildings
  - c) Pole or pad mount Central Metering System – grounding at utility transformer

**1) Background**

The Ontario Electrical Safety Code (OESC) provides *Equipotential bonding* requirements which may mitigate stray voltage effects in farms caused by the normal delivery and use of electricity. It should be noted the customer contribution to stray voltage can often be mitigated by design and preventative maintenance of the electrical system. For more information, please see ESA Guideline [Basic Troubleshooting of On Farm Stray Voltage](#).

**2) Equipotential bonding in milking areas**

**Issue**

Rule 10-700 e) requires the conductive metal parts of structures that livestock access be made equipotential with the non-current carrying conductive parts of electrical equipment (Bonded together) , in some cases, this has been found to be insufficient to mitigate the effects of stray voltage in milking areas of buildings housing livestock. In addition to the minimum requirements of Rule 10-700 e), ESA recommends the following;

- 1) Livestock waterers, wire mesh, grates, metallic water pipes, stanchions, water bowls, vacuum lines, grain feeders, gates, support posts, and other metals shall be bonded together by a separate stranded copper conductor not smaller than No. 6 AWG.
- 2) The metallic equipment bonded together as specified above shall be connected to the ground buss at the distribution panel by a separate copper conductor not smaller than No. 6 AWG. See Diagram B1.
- 3) In milking parlours, concrete floors are recommended to have a No. 9 gauge wire mesh, dimensions 15 cm × 15 cm (6 in × 6 in), and bonding should comply with the above requirements. See Diagram B2.

**Diagram B1 – Equipotential bonding in milking areas**

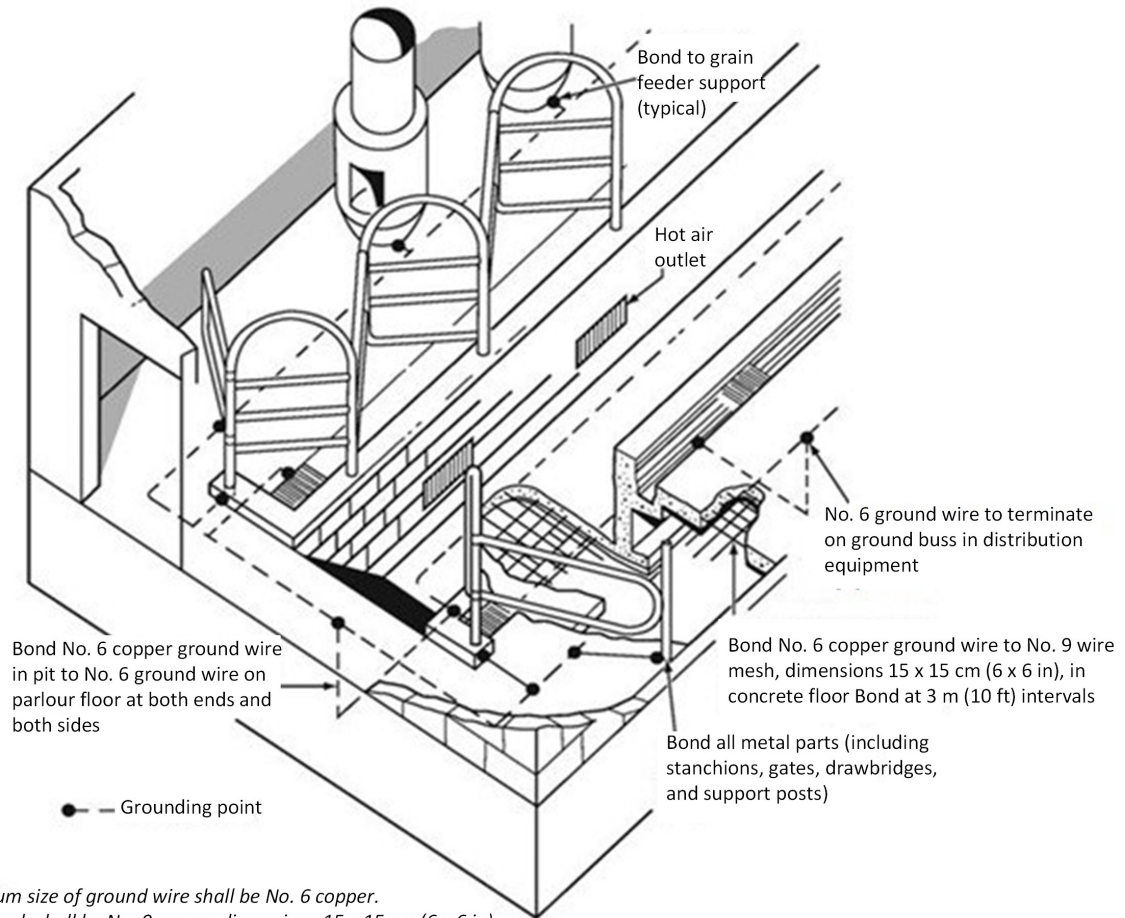

**Notes:**

- (1) Minimum size of ground wire shall be No. 6 copper.
- (2) Wire mesh shall be No. 9 gauge, dimensions 15 x 15 cm (6 x 6 in).
- (3) Wire mesh shall be bonded to ground wire at maximum intervals of 3 m (10 ft).
- (4) All steel posts, gate posts, support posts, feeder brackets, etc., shall be bonded to ground wire.
- (5) Angle iron grate supports for floor drains shall be bonded at both ends of parlour and both sides of grate.
- (6) Ground loop on floor of pit shall be connected to ground loop on floor parlour at both ends and both sides.
- (7) Grounding conductor size is given in American wire gauge.
- (8) For new and reconditioned existing parlours, wire mesh shall have concrete cover of 75 mm (3 in).

**Diagram B2- Wire mesh in concrete floors**

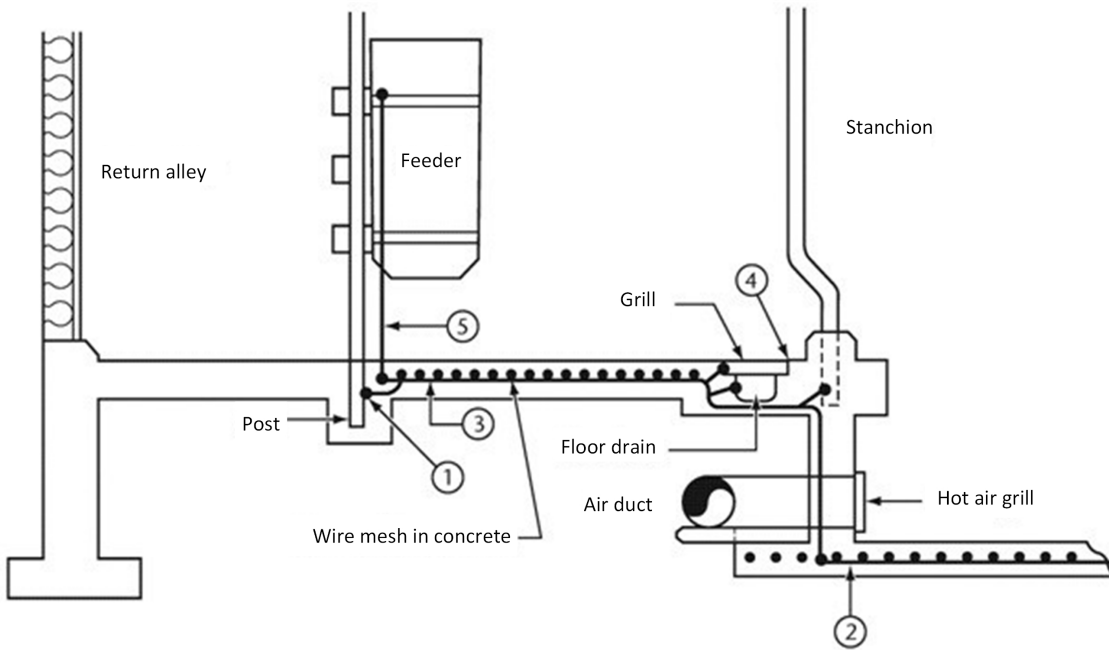

**Notes:**

- (1) All metal parts shall be bonded (including stanchion gates, drawbridges, and support posts).
- (2) No. 6 copper wire in parlour floor shall be bonded to No. 6 copper wire in pit at both ends and both sides.
- (3) No. 6 copper ground wire shall be bonded to No. 9 wire mesh, dimensions 15 x 15 cm (6 x 6 in), in concrete floor at 3 m (10 ft) intervals.
- (4) Angle iron grate supports for floor drains shall be bonded at both ends of parlour and both sides of grate.
- (5) See Detail 1.

**Detail 1**

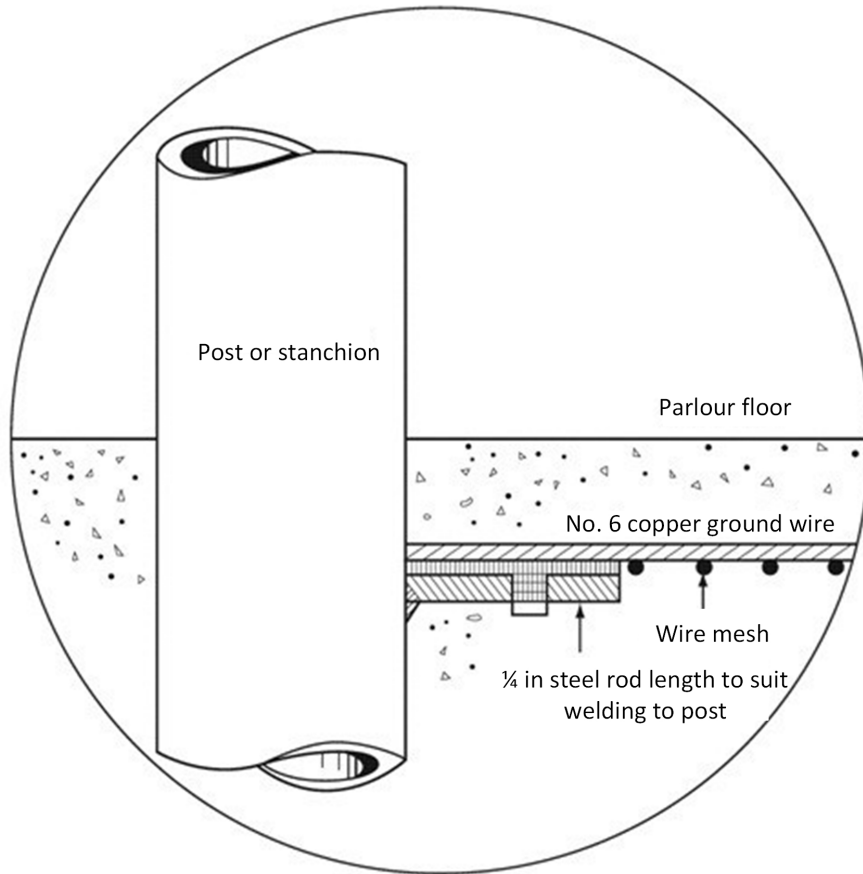

Wire mesh, ground wire and  $\frac{1}{4}$  in steel rod shall all be welded to ensure circuit continuity.

$\frac{1}{4}$  in round steel rod shall be welded to feeder - down to mesh.

$\frac{1}{4}$  in rod, mesh and No. 6 copper ground wire shall be welded together, 2 per side.

### 3) Grounding & bonding for farm buildings

#### a) Farm service

Rule 10-210 d) prohibits a connection between a *grounding conductor* and the *system neutral* after the *Service Box*. This means a bonding conductor must be installed with all feeders or branch circuits feeding any out building including buildings housing livestock when supplied from distribution equipment. (See Diagram B3)

**Diagram B3 – Grounding & Bonding of Building supplied from Distribution Equipment (Farm Service)**

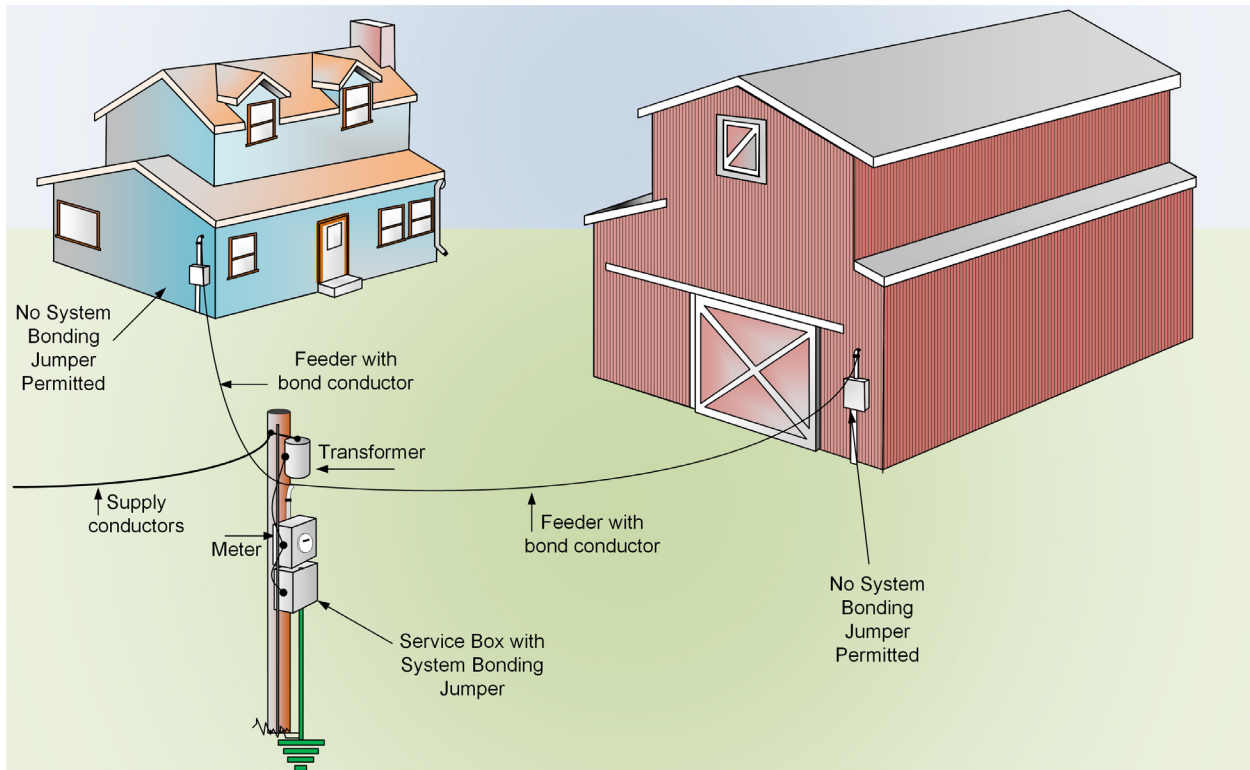

**b) Central metering system – grounding at individual buildings**

The feeders from a Pole or Pad Mount Central Metering System (CMS) supplying buildings are considered *Consumer's Services*. Rules 6-200 requires each building supplied by a *Consumer's Service* to have a *Service Box*. Rule 10-210 requires a *System Bonding Jumper* at the *Consumer's Service* (See Diagram B4).

Note – More than one *Consumer's Service* connected to a single building will result in objectionable current over grounding and bonding conductors which is not permitted per Rules 10-100 and 10-500 (Objection current over grounding and bonding conductors) connection in accordance with the requirements of topic (c) below will mitigate stray currents.

**Diagram B4 –CMS – grounding at individual buildings**

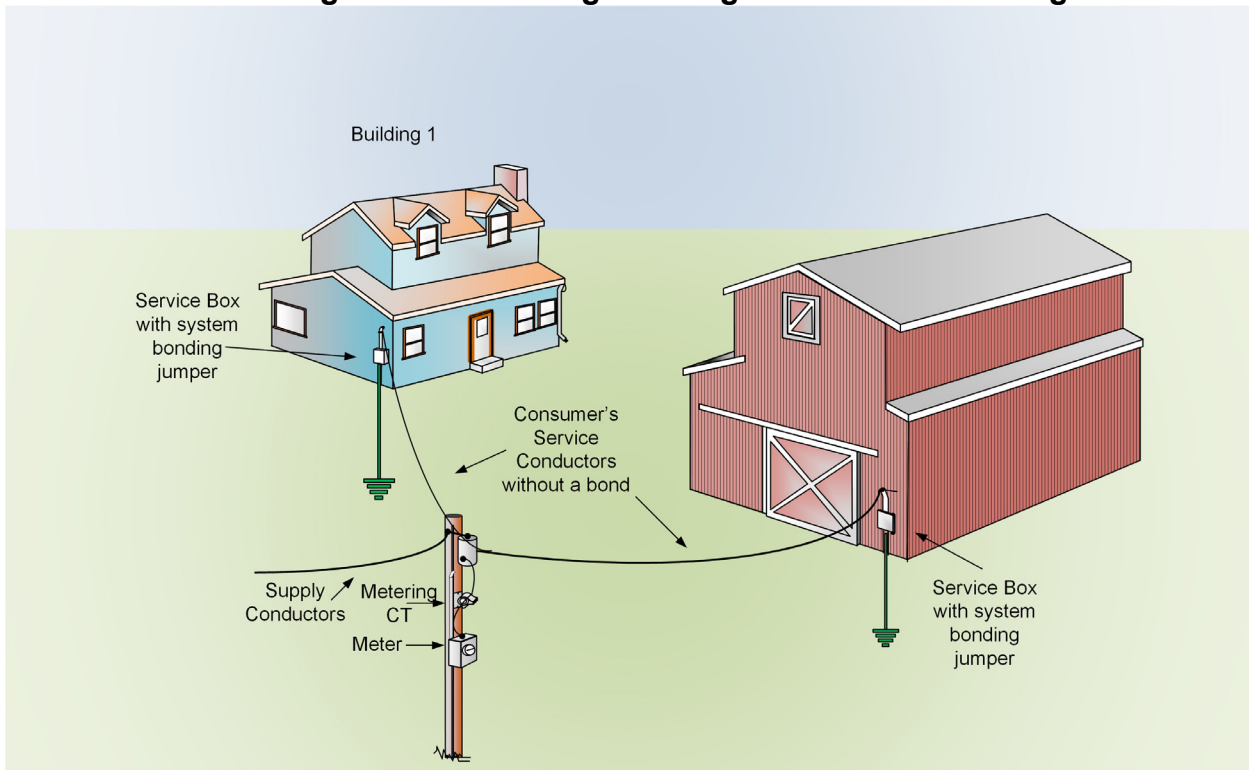

**c) Pole or pad mount Central metering system – grounding at utility transformer**

Research has shown that sometimes single point groundings may be effective in mitigating some stray voltage issues and designers may wish to utilize this option for a CMS however it is not permitted by the OESC. Notwithstanding rule 10-210, for buildings on farms supplied by a CMS it shall be permitted to eliminate the *System Bonding Jumper* from the *Service Boxes* when the *LDC* permits connection of a bonding conductor run with the *Consumer's Service* conductors to their transformer. (See Diagram B5)

**Diagram B5 –CMS - with separate bonding conductors**

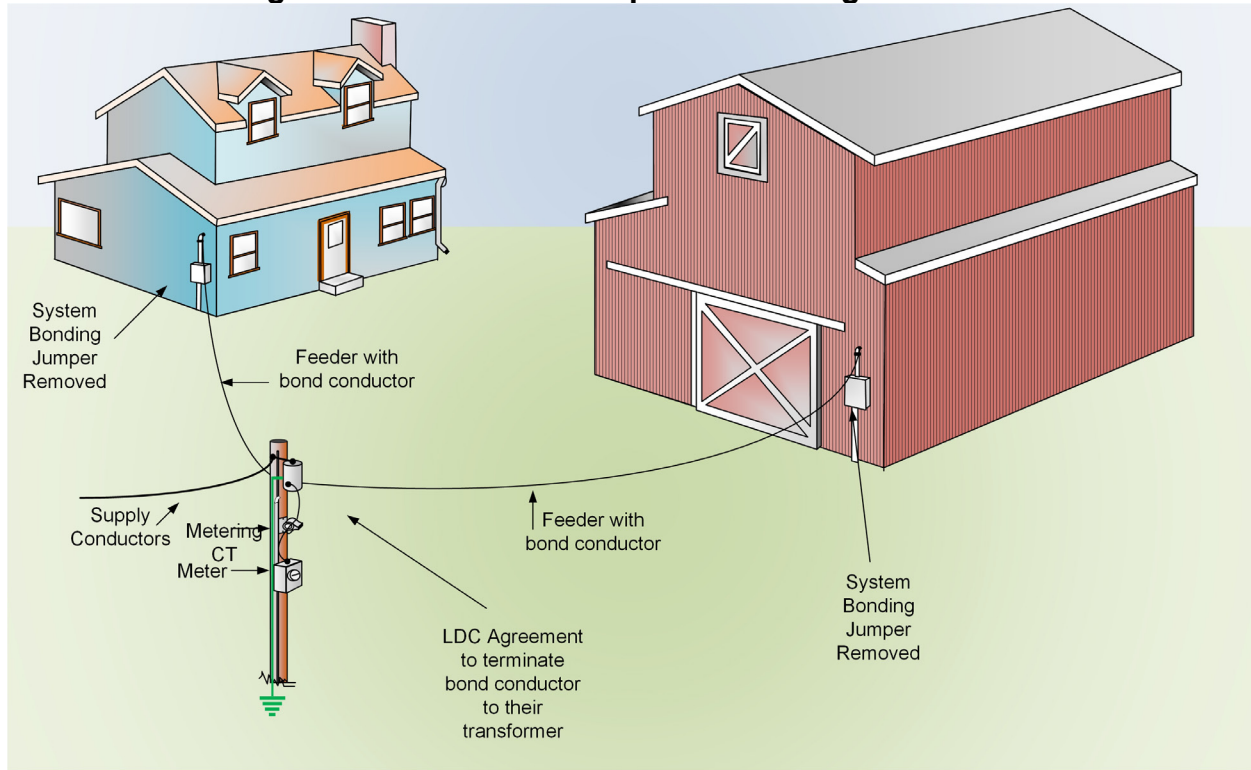

**Note**

Where overhead conductors are used to distribute 3-wire 120/240 V feeders, acceptable methods of installations for the conductors feeding a building include:

- Quadruplex Type NS75, with the bare conductor utilized as the bonding conductor. The neutral conductor is required to be insulated, and properly identified as per Rule 4-030;
- Triplex Type NS75, with the bare conductor utilized as the bonding conductor and a white neutral conductor lashed over the triplex conductors; or
- Triplex Type NS75, with the bare conductor utilized as the neutral conductor (not in contacted with bonded metal as per Rule 12-318) and a green conductor lashed over the triplex conductors.